

ILE-KNX-A00-PS640 | 05.2018

Application Manual

KNX Power Supply 640 mA

ILEVIA KNX SYSTEM

The worldwide
STANDARD for
Home & Building
Automation

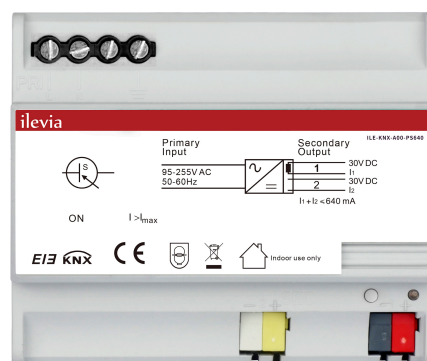

Art. Code
ILE-KNX-A00-PS640



Notes on the instruction manual	3
Safety	4
Intended use	4
Improper use	4
Target group / qualification of personnel	4
Liability and warranty	4
Environment	5
Product description	6
Description of functions	6
Overview of A00-PS640	6
Technical data	7
Parameters	7
Dimensions	8
Connection diagram	8
Mounting	9
Safety instructions for mounting	9
Installation / mounting	10
Electrical connection	10
Dismantling	10
Commissioning	11
Maintenance	12
Cleaning	12

1. Notes on the instruction manual

Please read this manual through carefully and adhere to the information contained therein. This will assist you in preventing damage to persons and property and ensure reliable operation and long service life of the device.

Please keep this manual in a safe place.

If you pass the device on, also include this manual.

If you require additional information or have questions about the device, please contact Ilevia S.r.l. or visit our Internet site at:

www.ilevia.com/support

2. Safety

2.1. Intended use

The device must only be operated within the specified technical data.

The EIB / KNX power supply is a rail mounting device for installing in the distributor. The device must only be installed in flush-mounted boxes in dry indoor rooms. The currently valid regulations must be adhered to.

2.2. Improper use

The device is dangerous if used improperly. Any non-intended use is deemed improper use. The manufacturer is not liable for damages resulting from such improper use. The associated risk is borne exclusively by the user/operator.

The device must never be used outdoors or in bathroom areas. Do not push objects through the openings in the device. Only the available options for connection are to be used in accordance with the technical data.

2.3. Target group / qualification of personnel

Installation, commissioning and maintenance of the product must only be carried out by trained and properly qualified electrical installers. The electrical installer must have read and understood the manual and follow the instructions provided. The operator must adhere to the valid national regulations in his country governing the installation, functional test, repair and maintenance of electrical products.

2.4. Liability and warranty

Improper use, non-observance of this manual, the use of inadequately qualified personnel, as well as unauthorized modification excludes the liability of the manufacturer for the damages caused. It voids the warranty of the manufacturer.

3. Environment

Always dispose of the packaging material and electric devices and their components via the authorized collecting depots and disposal companies.

This marking indicates that this product should not be disposed with other household wastes throughout the EU. To prevent possible harm to the environment or human health from uncontrolled waste disposal, recycle it responsibly to promote the sustainable reuse of material resources. To return your used device, please use the return and collection systems or contact the retailer where the product was purchased. They can take this product for environmental safe recycling.

4. Product description

4.1. Description of functions

EIB / KNX power supply produces and monitors EIB / KNX system voltage. The bus line is decoupled from the power supply with the integrated choke. The power supply is connected to the bus line with a bus connection terminal. A reset is triggered by pressing the reset push button and lasts 22 seconds (regardless of the duration of the push button action). The bus line is disconnected from the power supply and the devices connected to this bus line are returned to their initial state. If the line should be disconnected for a longer period, the bus connection terminal must be removed from power supply. A 30V DC auxiliary voltage is made available via an additional connection terminal. This voltage can be used to supply a further bus line (in connection with a separate choke).

4.2. Overview of A00-PS640

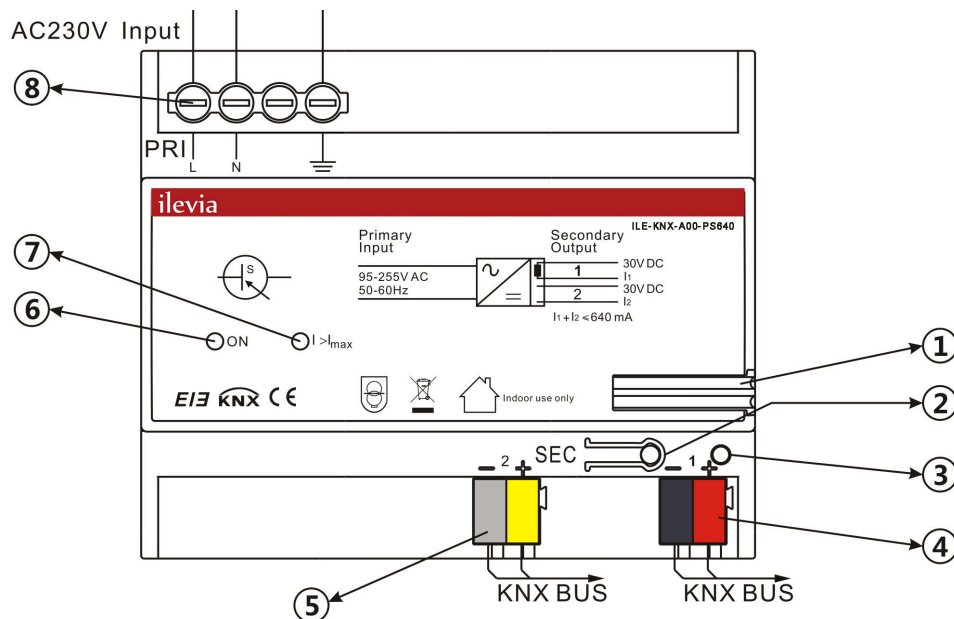

1. Label carrier
2. Reset push button
3. Red LED (Reset)
4. Bus connection terminal (EIB / KNX output)
5. Connection terminal (auxiliary voltage output)
6. Green LED (output voltage is ok)
7. Red LED (overload / short circuit)
8. Mains supply

5. Technical data

5.1. Parameters

Parameters	Value	
Power supply	Input voltage	95V ~ 255 Vac, 47 ~ 63 Hz
	Nominal value	30 V DC +1/-2 V, SELV
	Power loss	<6 W
	Efficiency	75%
Output	EIB / KNX output (DPSU)	1 line with integrated choke
	Auxiliary voltage output	1 (without choke)
	Auxiliary voltage	30 V DC +1/-1 V, SELV
	EIB / KNX nominal current	640 mA, short-circuit-proof
	Sustained short-circuit current	< 1.3 A
	Mains failure back-up time	>200ms
Display elements	Green LED "ON"	output voltage is OK
	Red LED "I>Imax"	overload or short circuit
	Reset push button	reset at the EIB / KNX output (22 sec)
	Red LED	reset at the EIB / KNX output
Connecting terminals	Power supply	2-screw terminals
	Cable cross-section	Single-core 0.2 — 4.0 mm ² Multi-core 0.2 — 2.5 mm ²
	EIB / KNX output	Bus connection terminal (black / red)
	Auxiliary voltage output	Connection terminal (yellow / grey)
Protection type	IP 00, EN 60529	
Ambient temperature	Operation	- 5 °C to + 45 °C
	Storage	- 25 °C to + 55 °C
	Transport	- 25 °C to + 70 °C
Mounting	On 35mm mounting rail	Acc. to DIN EN 60715
Design	Rail mounting device	Modular installation device
	Installation width	6 modules à 108 mm
	Installation depth	60 mm
	Housing, colour	Plastic, white
Dimension	90 x 108 x 60 mm (H x W x D)	
Weight	0.3 Kg	
CE marking	In accordance with the EMC guideline and the low voltage guideline	

5.2. Dimensions

All dimensions are in mm.

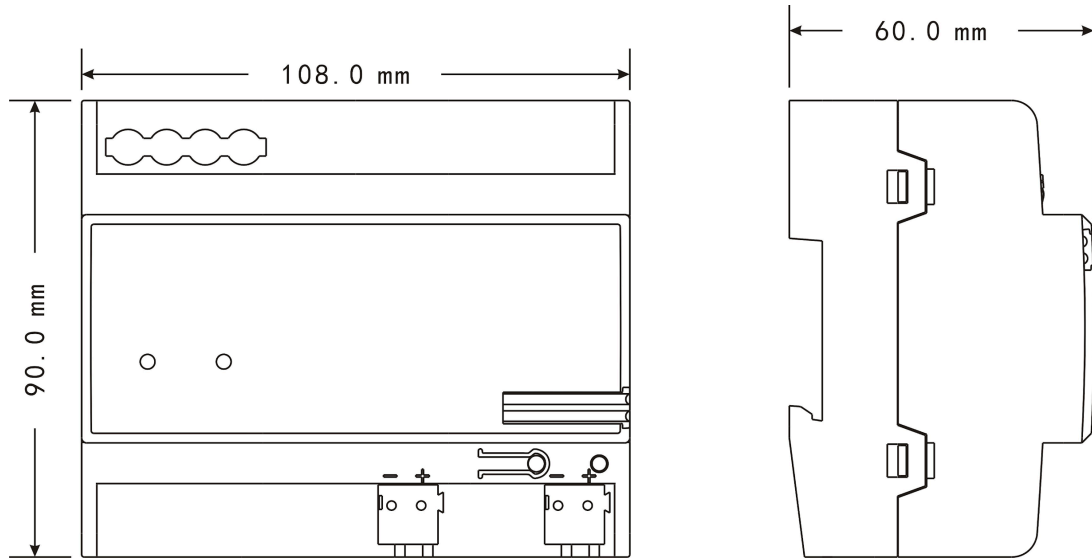

5.3. Connection diagram

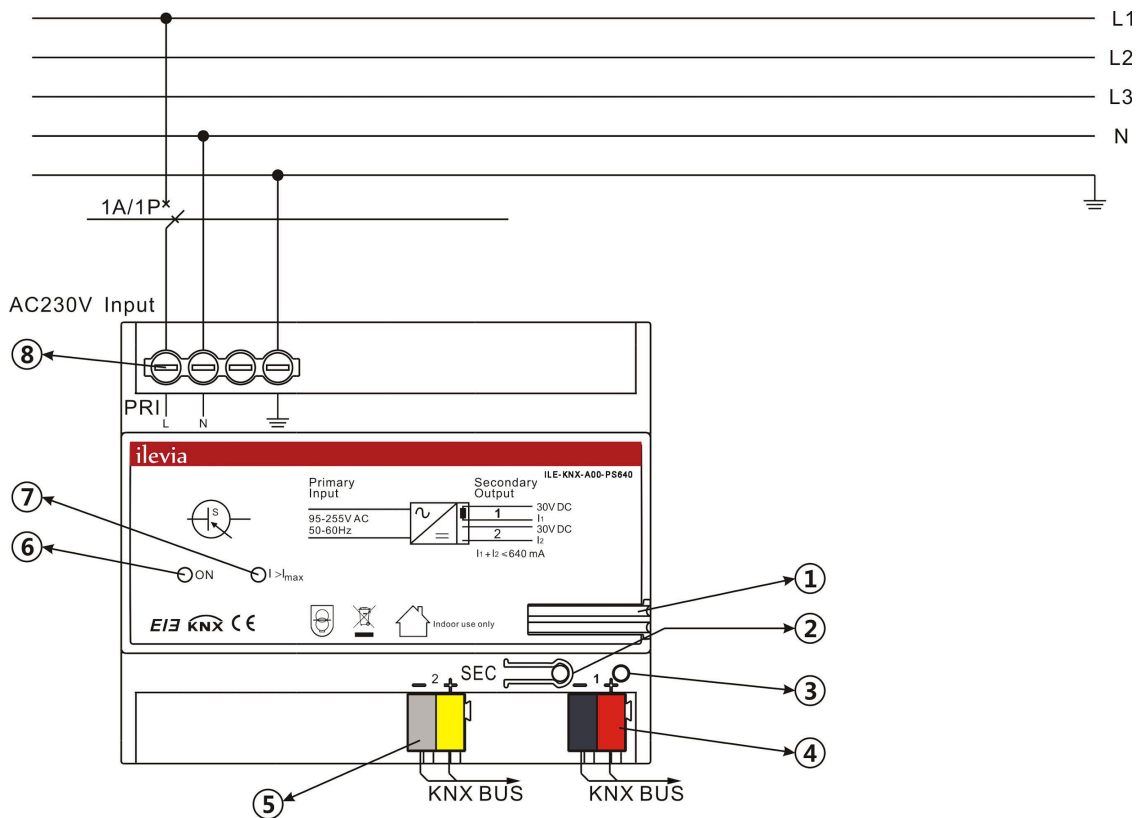

6. Mounting

6.1. Safety instructions for mounting

DANGER! Risk of death due to electrical voltage.

Dangerous currents flow through the body when coming into direct or indirect contact with live components. This results in electric shock, burns or even death.

Work improperly carried out on electrical systems is a hazard to one's own life and that of the user. Also fires and serious damage to property can result.

- » Observe the relevant standards.
- » Apply at least the "five safety rules":
 1. Disconnect
 2. Secure against being re-connected
 3. Ensure there is no voltage
 4. Connect to earth and short-circuit
 5. Cover or barricade adjacent live parts
- » Install the device only if you have the necessary electrical engineering knowledge and experience.
- » Use suitable personal protective clothing.
- » Use suitable tools and measuring devices.
- » Check the supply network type (TN system, IT system, TT system) to secure the following power supply conditions (classic connection to ground, protective earthing, necessary additional measures, etc.).

DANGER! Risk of death due to short-circuit.

Risk of death due to electrical voltage of 230V during short-circuit in the low-voltage line.

- » During mounting observe the spatial division (> 10 mm) of SELV electric circuits to other electric circuits.
- » Observe the spatial division of SELV electric circuits and other electric circuits. Otherwise short-circuits can occur.
- » If the minimum distance is insufficient, use electronic boxes or insulating tubes.
- » Observe the correct polarity.

6.2. Installation / mounting

The device is a rail mounting device for installing in distributors for easy installation on 35 mm mounting rails according to DIN EN 60 715.

The device can be mounted in any position.

The bus connection is established by means of the enclosed bus connection terminal.

The device is ready for operation after the operating voltage has been applied.

The description of the terminals is found on the housing.

Access to the device must be guaranteed for operation, testing, inspection, maintenance and repairs according to DIN VDE 0100-520.

6.3. Electrical connection

- » The electrical connection is made via screw terminals. The bus connection is established by means of the enclosed bus connection terminal. The terminal designation is located on the housing.
- The device is ready for operation after the operating voltage has been applied.

Mounting and commissioning must only be carried out by qualified electrical installers. When planning and setting up electrical systems and security-related systems for the detection of intrusion and of fires, the relevant standards, guidelines, rules and regulations of the respective country are to be observed.

- » Protect the device against humidity, dirt and damage during transport, storage and operation!
- » Operate the device only within the specified technical data!
- » Operate the device only in a closed housing (distributor)!
- » Prior to performing installation work the device is to be deactivated.

DANGER! Danger to life.

To prevent dangerous contact currents due to feedback from different external conductors, an all-pole deactivation is to be carried out when extending or changing the electric connection.

6.4. Dismantling

Dismantling is carried out in the reverse order.

7. Commissioning

After the power supply has been connected the device is fully functional without further commissioning.

8. Maintenance

The devices are maintenance-free. In case of damage (e.g., during transport or storage), do not perform repairs. Once the device is opened, the warranty is void! Access to the device must be guaranteed for operation, testing, inspection, maintenance and repairs (according to DIN VDE 0100-520).

8.1. Cleaning

Dirty devices can be cleaned with a dry cloth. If this is not sufficient, a cloth slightly moistened with a soap solution can be used. Caustic cleaning agents or solvents must not be used.



Ilevia S.r.l.

Quartiere Prè 45, 36061
Bassano del Grappa, Italy

Telephone: +39 0424 480034

E-mail: info@ilevia.com

www.ilevia.com

Further information and contact:



Note:

We reserve the right to make technical modifications to products as well as changes to the content of this document without prior notice. The respective agreed-upon conditions apply to orders. Ilevia accepts no responsibility for possible errors or incompleteness in this document.

We reserve all rights to this document and the topics and illustrations contained therein. Duplication, disclosure to third parties or the use of its contents - and of parts thereof - is forbidden without prior written approval from Ilevia S.r.l..

Copyright © 2018 Ilevia

All rights reserved.